

JACKSON

Model 5090 Mobile Container Cart

CAPACITY:
Maximum 1,500 lbs.
evenly distributed.

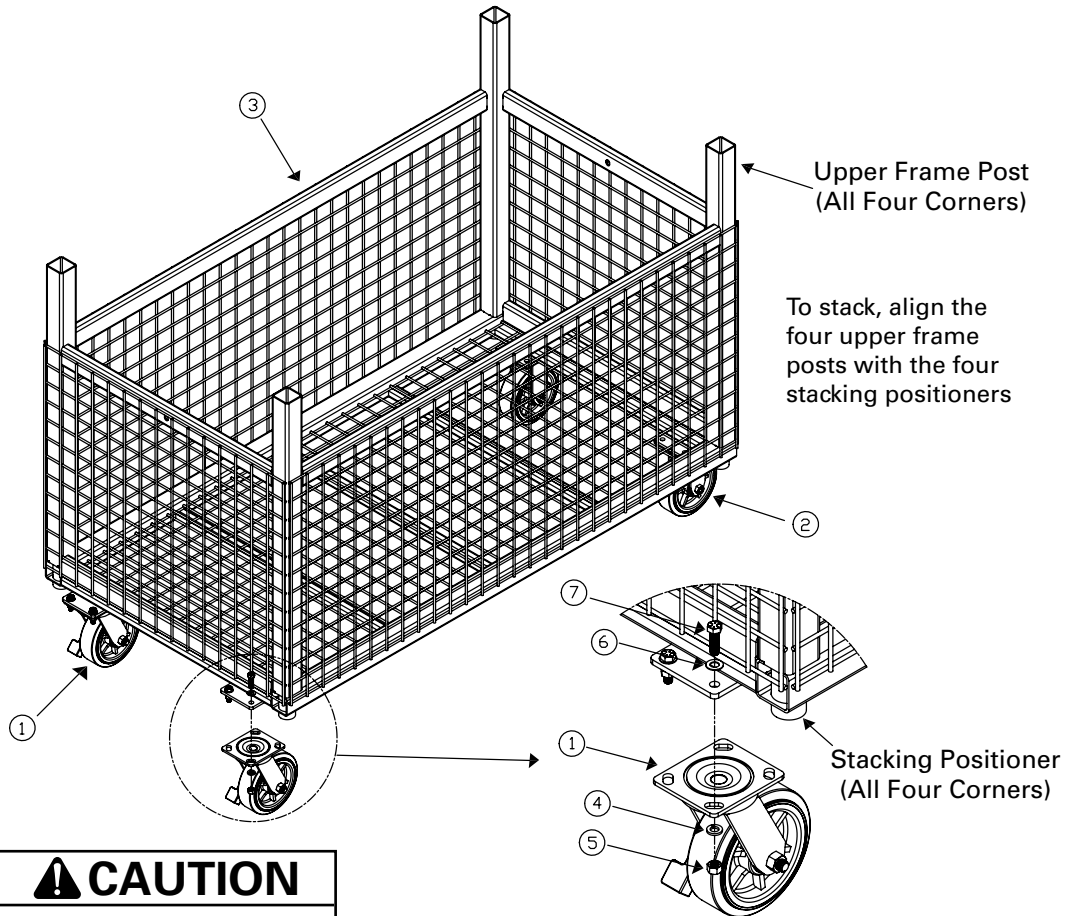

CAUTION
Maximum stacking height is two (2) carts.

CAUTION
DO NOT roll mobile container carts while stacked.

CAUTION
ONLY roll single, unstacked mobile container cart on a firm, flat, smooth surface.

INSTRUCTION SHEET AND PARTS LIST

PARTS LIST — 5090 MOBILE CONTAINER CART

ITEM#	PART#	QTY	DESCRIPTION
1	513-001	2	CASTER – SWIVEL
2	513-002	2	CASTER – FIXED
3	5090-210	1	FRAME
4	452-27	16	3/8 LOCK WASHER

ITEM#	PART#	QTY	DESCRIPTION
5	452-28	16	3/8 HEX NUT
6	506-3	16	WASHER – FLAT 3/8 (USS) ZINC
7	524-11	16	SCREW – HEX HEAD CAP GR5 ZINC (3/8-16 × 1")

02/2023

Read and understand this material before operating the Mobile Container Cart. Failure to understand how to safely operate this Mobile Container Cart may result in injury or property damage.

This manual is free of charge. All personnel who operate the Mobile Container Cart should have a copy of this manual and read and understand its contents. To request a copy of this manual or replacement safety decals, or for technical assistance, call or write to the address below. All information, specifications and product designs may change due to design improvements or updates and are subject to change without notice. Current Tools does not assume any liability for damages resulting from misuse or incorrect application of its products.

JACKSON TOOL • P. O. BOX 5701 • GREENVILLE, SC 29606
877-522-8995 or 864-721-4235 • FAX 864-721-4236 • www.jacksonstoolinc.com