

JACKSON

Model 458 Pipe Wagon

12/10 - REV. 0

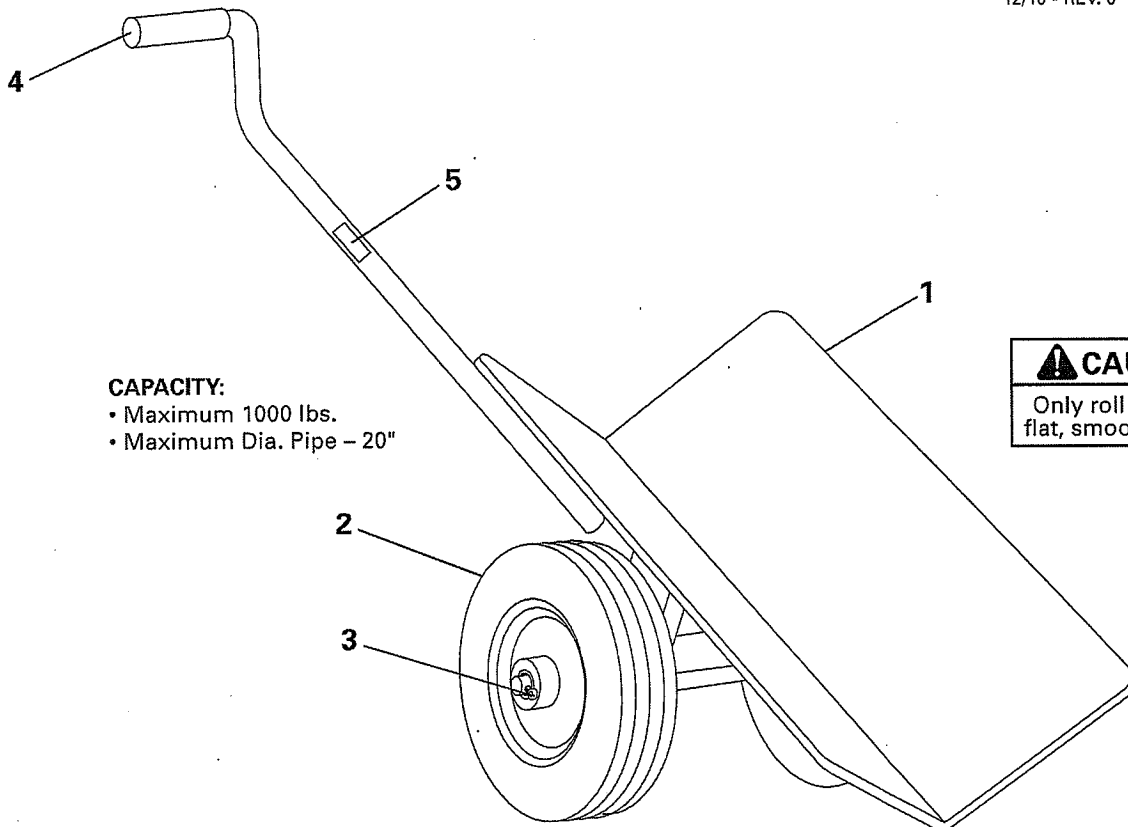

INSTRUCTION SHEET AND PARTS LIST

PARTS LIST — 458 PIPE WAGON

ITEM #	PART#	QTY	DESCRIPTION
1	458-237	1	FRAME
2	458-2	2	WHEEL
3	2508-9	2	COTTER PIN $\frac{3}{16}$ " X 2"
4	458-4	1	GRIP
5	458-5	1	DECAL



Read and understand this material before operating or servicing the Pipe Wagon. Failure to understand how to safely operate and service this Pipe Wagon may result in injury or property damage.

This manual is free of charge. All personnel who operate the Pipe Wagon should have a copy of this manual and read and understand its contents. To request a copy, call or write to the address below.

JACKSON TOOL, INC. • P. O. BOX 5701 • GREENVILLE, SC 29606
877.522.8995 OR 864.244.2544 • FAX 864.244.2128 • www.jacksonstoolinc.com