

JACKSON

Model 536P Pipe Horse with Phenolic Wheels

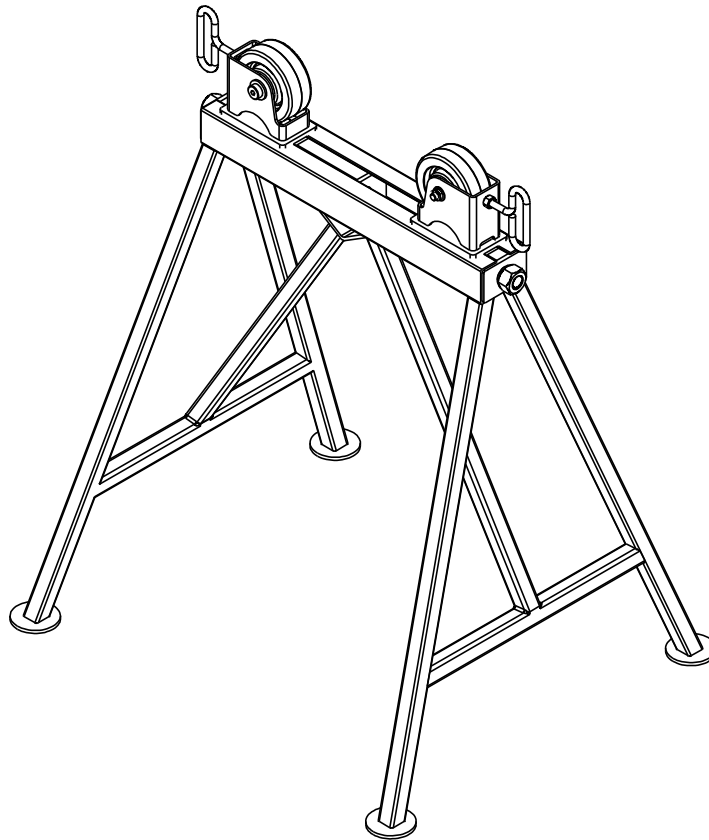

Operating, Safety and Parts Manual

04/17



Read and understand this material before operating or servicing the Pipe Horse. Failure to understand how to safely operate and service this unit may result in property damage, serious injury or death.

This manual is free of charge. All personnel who operate this Pipe Horse should have a copy of this manual and read and understand its contents. To obtain a copy, call, write to the address below, or visit our website.

JACKSON TOOL • P. O. BOX 5701 • GREENVILLE, SC 29606
877-522-8995 or 864-721-4235 • FAX 864-721-4236 • www.jacksonstoolinc.com

TABLE OF CONTENTS

<i>Safety Alerts</i>	2
<i>Safety Information</i>	3
<i>Features</i>	3
<i>Specifications</i>	4
<i>Operating Instructions</i>	4
<i>Exploded View</i>	5
<i>Parts List</i>	5

SAFETY ALERTS



Safety Alert Symbol

THIS SAFETY SYMBOL is used to call your attention to instructions that concern your personal safety. It means: ATTENTION! BE AWARE! THIS IS AN IMPORTANT SAFETY INSTRUCTION!

Read, understand and follow these safety instructions. Failure to follow these safety instructions may result in injury or death.



DANGER

Immediate hazards which, if not avoided, WILL result in serious personal injury or death.



WARNING

Hazards or unsafe practices which, if not avoided, COULD result in serious personal injury or death.



CAUTION

Hazards or unsafe practices which, if not avoided, COULD result in minor personal injury or property damage.

RETAIN SAFETY INFORMATION



This manual should be read and understood by all personnel who operate or service this Pipe Horse. Failure to understand how to safely operate and service this unit could result in injury or death. This unit should only be operated or serviced by qualified personnel.

IMPORTANT SAFETY INFORMATION

Follow ALL safety information provided by the manufacturer.

- ⚠ WARNING** ALWAYS place the Pipe Horse on a smooth, level, firm surface that will support the weight of the load. NEVER use on dirt or gravel surface. Be sure all feet of the Pipe Horse make contact with the floor.
- ⚠ WARNING** ALWAYS be sure the pipe is properly placed onto the Pipe Horse. Improperly loaded pipe can cause tipping of the Pipe Horse, falling pipe and serious injury.
- ⚠ WARNING** ALWAYS inspect the Pipe Horse before each use. Never use if any legs or other part of the Pipe Horse is bent, deformed or broken.
- ⚠ WARNING** NEVER adjust the rollers with pipe loaded on the Pipe Horse.
- ⚠ WARNING** NEVER exceed the maximum rated capacity of the Pipe Horse.
- ⚠ WARNING** NEVER alter the Pipe Horse. Only use the Pipe Horse for its designed purpose.
- ⚠ WARNING** NEVER drop pipe onto the Pipe Horse.
- ⚠ WARNING** NEVER allow anyone under the pipe while it is supported by the Pipe Horse.
- ⚠ CAUTION** ALWAYS wear gloves and other safety equipment for your specific job when using the Pipe Horse.

FEATURES

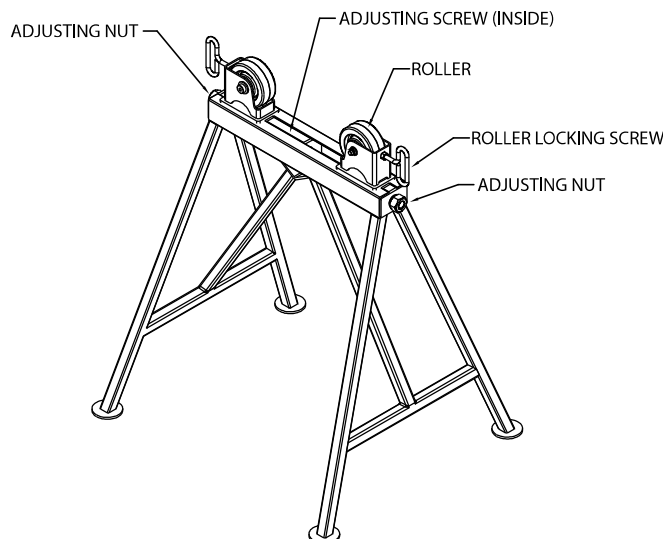

SPECIFICATIONS

Model No.	536P
Pipe Size Capacity	1/2" to 36"
Max. Weight Capacity	1000 lbs. per Pipe Horse
Overall Dimensions	L 27" W 23½" H 32½"
Weight	35 lbs.

OPERATING INSTRUCTIONS

1. Inspect the Pipe Horse before each use. Never use if any legs or any other part of the Pipe Horse is bent, deformed or broken. Never modify or use a Pipe Horse that has been modified.
2. Place the Pipe Horse on a smooth, level, firm surface that will support the weight of the load. Be sure all feet of the Pipe Horse are making contact with the floor.
3. Using the adjusting nut at either end of the Pipe Horse, adjust the rollers for the size pipe you will be loading onto the Pipe Horse.
4. Always support the pipe with a minimum of two (2) Pipe Horses. Pipe size, weight and length are some of the factors to consider when supporting pipe with the Pipe Horses.
5. Place the pipe onto the Pipe Horses. Never drop the pipe onto the Pipe Horses. Never exceed the maximum rated capacity of the Pipe Horses. Never adjust the rollers with the pipe loaded on the Pipe Horses.

To avoid tipping, the Pipe Horses should be properly aligned so that the pipe rests on both rollers of each Pipe Horse being used. Never allow anyone under the pipe while it is supported by the Pipe Horses.

6. Each roller on the Pipe Horse has a roller locking screw. Tightening the screw will prevent the roller from turning.

EXPLODED VIEW — 536P PIPE HORSE

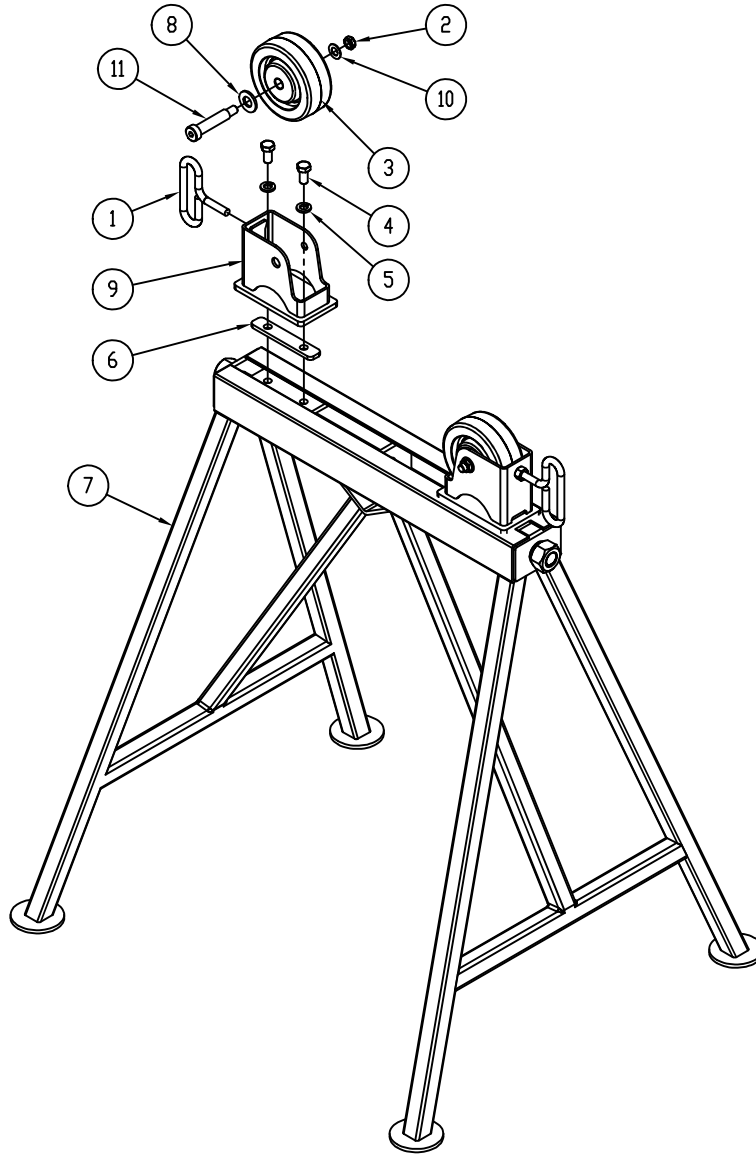

PARTS LIST — 536P PIPE HORSE

<u>ITEM#</u>	<u>PART#</u>	<u>QTY</u>	<u>DESCRIPTION</u>
1	2508-581	2	Screw, "T" Handle
2	302-2	2	Nut – Hex, 3/8-16 (Nyl Insert Thin)
3	437-103	2	Wheel – Phenolic
4	536-4	4	3/8-16 X .75 LG HHCS
5	536-5	4	3/8 Lock Washer
6	536-839	2	Spacer
7	536-845	1	Main Frame
8	536P-001	2	Washer, Flat, 1/2" SAE
9	536P-101	2	Roller Bracket
10	5633WC-041	2	Washer – Flat 3/8 (USS) Zinc
11	636-4	2	Screw – Shoulder, Socket (1/2 X 2)